

ALPHA

CODED AUDIO

ACCESS CONTROL SYSTEMS

INSTALLATION AND PROGRAMMING INSTRUCTIONS



ISSUE : 002/UK

REF : ALPHA_CA.PPP

DECA CONTROL UNIT - FRONT PANEL

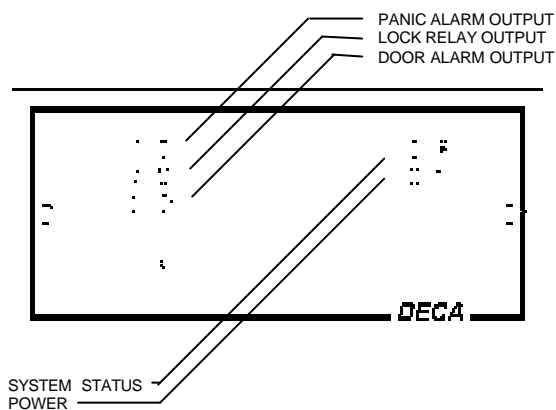

MAIN FEATURES

- * DOOR PANEL/KEYPAD TYPES - Aluminium, S/Steel, & Polished Brass
- * MULTIPLE CODE OR COMMON CODE VERSIONS - To aid system design
- * USER FRIENDLY SET UP - With tone and LED indication of system state
- * ACCESS CODES - Can be 24 hour or time zoned
- * PROGRAMMERS CODE - For ease of use and front end security
- * SHUT DOWN MODE - Allowing keypad functions to be shut down
- * ON/OFF MODE - Allowing lock output to be used as a switch
- * BLEEP MODE FOR THE PARTIALLY SIGHTED - For audio location of keypad
- * DURESS ALARM - To indicate entry of code numbers under duress
- * DOOR OPEN ALARM - With programmable door open time and auto reset
- * TAMPER ALARM - Will inhibit system for invalid code entries
- * MULTIPLE DOOR INTERLOCK - Allows groups of doors to be interlocked
- * EXIT PUSH BUTTON INPUT - Fully processed to allow interlock feature
- * TIME SWITCH INPUT - To provide time zoning of access & control codes
- * CLEAR DOWN MODE - To clear down all access codes & reset defaults
- * LOCK AND ALARM RELAY OUTPUTS - 2 amp volt free change over contacts
- * POWER SUPPLY - Either a simple 12v AC or DC supply

SYSTEM DESIGN

ALPHA CODED AUDIO Access Systems are simple to install, simple to program combined audio door entry and digital access kits. The systems can be used for single door single code & single phone applications or by purchasing additional equipment more complex multiple door installations. The advantages of the 100 code system over the two code system is that authorised personnel (upto 100 individuals) can select their own 4 digit code, which when required, can be deleted without affecting other users as each individual's code is unique. In multiple door installations the keypad can be programmed to restrict specific codes at specific doors, i.e. all personnel would be allowed through the main entrance but

only accounts personnel into the accounts office etc. An audit trail of entry events can be logged by using the DECA Printer Interface and downloaded onto a dot matrix parallel printer. Any of the DECA access control systems may be enhanced with an Audio or an audio/visual upgrade. This will allow audio only or audio/visual communication and remote operation of the door lock for unauthorised personnel. Use either the DECA kits complete with a keypad, control unit, standard lock release and AC power supply or use the keypad and control unit with any 12v AC or DC PSU and any locking device failsafe/failsecure upto 2 amps. For locking devices drawing more than 2 amps use an interface relay.

OVERVIEW

MULTIPLE CODE & COMMON CODE SYSTEMS

The ALPHA Coded Audio system is available in two versions, multiple code units (100 access codes) and common code unit (2 access codes) both units are identical in both feature output and programming.

TIME ZONES

A time switch with isolated contacts may be connected to the controller to allow time zoning of access codes and control codes. Any access code or control code may be time zoned, this is done when the code is entered (see programming options). Time zoned codes will only operate when the time switch input is shorted.

DOOR CONTACT

A standard normally closed magnetic contact needs to be fitted to the controlled door if all of the system features are to be taken advantage of. If a door contact is not fitted then the following features are lost:

1. Lock output cut-off 2 seconds after door has opened
2. Door open alarm
3. Multiple door interlock

MULTIPLE DOOR INTERLOCK

This feature allows two or more doors to be interlocked together allowing only one of the group to operate at a time. The interlock feature monitors the door position via the door contact and internally if the lock output is powered, if any of the doors in the group are unsecure due to either state then all doors connected to the group are inhibited.

EXIT PUSH BUTTON

The exit push button input should be used to activate the lock output when manual operation of a door is either not possible or not desirable. The input is designed to accept a normally open contact, and is fully processed to take account of the interlock feature.

DURESS ALARM

If an access code is entered preceded by an * (ie. *3344) the lock output will operate in the normal way and in addition the PA Alarm output will operate for its programmed time.

P.A. ALARM

If the * and # buttons are pressed together the PA Alarm output will operate and the system will shut down for its programmed time. The alarm time setting defaults to 30 secs, but may be varied by using option "50".

PROGRAMMERS CODE

The programmers code is the first six digits (*# excluded) to be keyed in after depressing the program code switch following power up (depress switch through hole in front panel). The system will then enter the programmers mode. Valid programming entries are signalled by 2 short bleeps. Incorrect entries are ignored and signalled by 6 long bleeps. When in the programmers mode the system LED (Yellow) will be on and both the keypad and the controller sounders will operate, the sounders will give 2 bleeps (high and low tone) every 10 seconds. To leave or re-enter the program mode, enter the programmers code preceded by a #

The programmers code may be changed at any time after initial set up from within the programmers mode by using option "00".

ACCESS CODES

The Access Codes are 4 digit codes, held in code locations, and may be constructed of any 4 digits 0-9 (excluding * #) any digit may be used more than once (ie 3344). NOTE: The system will not allow codes to be duplicated (ie the same code in two different locations) Code locations are numbered as follows:
Common Code System (2 codes) 00 - 01
Multiple Code System (100 codes) 00 - 99
Access codes may be entered or deleted from the system by using option "10" and "20" respectively from within the programmers mode.

LOCK OUTPUT TIME

The lock output time can be programmed to operate for a set duration in either seconds, option "30" or in hours & minutes, option "31". The seconds feature is normally used for all access control applications and the hours & minutes setting for control of squash court lighting, snooker tables, sun beds etc.

When the lock output time is set in hours & minutes the lock output operation is modified in that when the system detects a valid access code the lock output will turn on for the programmed time, however the programmed time will be cut short if a valid access code is used again. The lock output time defaults to 5 seconds but may be varied by using either option. NOTE: If a door contact is fitted the lock output will turn off 2 seconds after the door has been opened ensuring that the door is secure on closing.

DOOR OPEN ALARM DELAY TIME

With a standard (N/C) magnetic door contact fitted to the door, the controller will monitor the door open time, if the door is open for longer than the programmed time, the door alarm output will operate and continue to operate until 15 seconds after the door has been closed. The door open alarm delay time defaults to 30 secs. but may be varied by using option "40".

NOTE: THE DOOR CONTACT INPUT TERMINALS IN THE CONTROLLER MUST BE SHORTED WITH A WIRE LINK IF A DOOR CONTACT IS "NOT" FITTED.

TAMPER ALARM TIME

If 13 invalid key strokes are made the door alarm output will operate and the system will shut down for the programmed time. The tamper alarm time defaults to 5 secs. but may be varied by using option "60".

CLEAR ALL ACCESS CODES, CONTROL CODES AND SET DEFAULTS

This mode will clear all access codes, control codes and reset all programmable timings to their default values.

NOTE: The program code will remain unchanged. The clear down mode is activated by using option "70" and the fixed password 654321, the clear down will take a few seconds to complete.
Default Values:

Lock output time - - - 5 seconds
Door open time - - - - 30 seconds
Tamper shutdown time - 5 seconds
PA Alarm time - - - - 30 seconds

TEST MODE

The test mode option "90" allows the keypad wiring, lock output and alarm outputs to be tested. Each key should be pressed in sequence 0123456789#. A problem will be indicated by 6 long bleeps. After entering the last digit (#) the lock output will turn on, press the * key to move on and step through the other outputs.

NOTE: If no keys are pressed the output will stay turned on for two minutes then step to the next output etc.

ON/OFF CODE

This code, when entered with the system in normal running mode, will allow the output to be used as a switch. When a valid code is entered the lock output will turn on and remain on until a valid code is entered again turning the output off. The system will remain in this mode until the ON/OFF code is re-entered restoring the system to full function. To set the ON/OFF code enter the program mode and use option "97". This sets the code and when entered preceded by a # the system will function as above.

SHUTDOWN CODE

This code, when entered with the system in normal running mode, will shutdown valid access codes but leave the other system features operating. It may be used by management for holiday shutdown periods etc. The system will remain in this mode until the shutdown code is re-entered restoring the system to full function. To set the shut down code enter the program mode and use option "98". This sets the code and when entered preceded by a # the system will function as above.

BLEEP CODE FOR THE PARTIALLY SIGHTED

This code, when entered with the system in normal running mode, will make the keypad sounder "chirp" every 12 seconds. This is to assist partially sighted users in locating the device. The system will remain in this mode until the bleep code is re-entered. To set the bleep code enter the program mode and use option "99". This sets the code and when entered preceded by a # the system will function as above.

INSTALLATION

COMBINED DOOR PANEL & KEYPAD

Install on the unsecure side of the door adjacent to the opening edge of the door.

TELEPHONE HANDSET

Install on the secure side of the door within 100 metres of the door panel.

CONTROL UNIT

Install on secure side of door within 100 metres of keypad.

DOOR CONTACT

Fit to the leading edge of the opening door. If the door contact is not fitted the following features will be inoperative:

1. Lock output cut-off 2 seconds after door has opened
2. Door open alarm
3. Multiple door interlock

NOTE: THE DOOR CONTACT INPUT TERMINALS IN THE CONTROLLER MUST BE SHORTED WITH A WIRE LINK IF A DOOR CONTACT IS "NOT" FITTED.

LOCK RELEASE

Fit the door release to the frame in place of the existing lock keep.

POWER SUPPLY

Install the power supply on the secure side of the door and feed via a 5 Amp fused 240v 50Hz mains outlet.

TIME SWITCH

INSTALLATION & PROGRAMMING

Install the time switch adjacent to the controller to provide time zoning of cards.

EXIT PUSH BUTTON

If required fit a normally open push button on the secure side of the door.

DOOR ALARM

If required fit a door alarm on the secure side of the door this will be activated by the tamper alarm & door open alarm.

PA ALARM

If required fit a PA alarm on the secure side of the door this will be activated by the duress feature & the PA alarm.

MULTIPLE DOOR INTERLOCK

If required wire between each controller that is to be interlocked.

CABLING

Door Panel power supply 2 cores
Door Panel telephone 5 cores
Door panel controller 9 cores
Door Contact controller 2 cores
Time switch controller 2 cores
Exit push button controller 2 cores
Door Alarm controller 2 cores
PA Alarm. controller 2 cores
Lock Release controller 2 cores
Power Supply controller 2 cores
Interlock controller to controller . . . 2 cores

PROGRAMMING

INITIAL SET-UP

- Double check all connections and power up the system.
- Depress the programmers code switch through the 2mm hole in the controller front panel & the system LED (yellow) will come on.
- Select your programmers code (6 digits excluding * or #) and enter at the keypad, this takes you straight to the program mode.
NOTE: When in the programmers mode the system LED (Yellow) will be on and both the keypad and the controller sounders will operate, the sounders will give 2 bleeps (high and low tone) every 10 seconds while in the programmers mode. Valid programming entries are signalled by 2 short beeps. Incorrect entries are ignored and signalled by 6 long bleeps.
- Clear the system & reset the default values using option "70".
- Enter an access code using option "10".
- Leave the programmers mode by entering the six digit programmers code preceded by a #.
- Test the system by entering the 4 digit access code at the keypad
- To re-enter or leave the program mode, enter the programmers code preceded by a #.
- Complete the Access Code Allocation sheet and keep secure.

PROGRAMMING OPTIONS

CHANGE THE PROGRAM CODE

00*(NEW CODE 6 digits)*

ENTER AN ACCESS CODE

10*(CODE LOCATION 2 digits)*(ACCESS CODE 4 digits)* Standard
10*(CODE LOCATION 2 digits)*(ACCESS CODE 4 digits)* Timed
(ie. 10*00*3344* = access code 3344 in code location 00)

DELETE AN ACCESS CODE

20*(CODE LOCATION 2 digits)*
(ie. 20*01* = access code in location 01 deleted)

SET THE LOCK OUTPUT TIME (Secs) for access control.

30*(SECS. 3 digits)*
(ie.30*009* = lock output set for 9 secs. Max time 120 secs)

SET THE LOCK OUTPUT TIME (Hours & Mins) for lighting etc.

31*(HOURS 1 digit)*(MINUTES 2 digits)*(ie. 31*1*09* = lock output set for 1 hour 9 mins. Max time 9 hours)

DOOR OPEN ALARM DELAY TIME

40*(SECS. 3 digits)*(ie. 40*060* = door open time set for 60 secs. Max time 120 secs.)

SET PA ALARM TIME

50*(SECS. 3 digits)*(ie. 50*100* = PA alarm set for 100 secs. Max time 120 secs)

SET TAMPER SHUT DOWN TIME

60*(SECS. 3 digits)*(ie. 60*009* = tamper shut down set for 9 secs. Max time 120 secs.)

CLEAR ACCESS CODES, CONTROL CODES (not prog.code) & SET DEFAULT VALUES

70*654321*(ie. 70*654321* = access & control codes cleared, defaults reset)

TEST MODE

90 * 0 1 2 3 4 5 6 7 8 9 *# Step through outputs by pressing *ie.
90*0123456789*#*** = if reported OK keypad & outputs tested)

SET THE ON/OFF CODE

97*(CODE 6 digits)*Standard 97*(CODE 6 digits)*Timed

SET THE SHUT DOWN CODE

98*(CODE 6 digits)*Standard 98*(CODE 6 digits)*Timed

SET THE BLEEP CODE

99*(CODE 6 digits)*Standard 99*(CODE 6 digits)*Timed

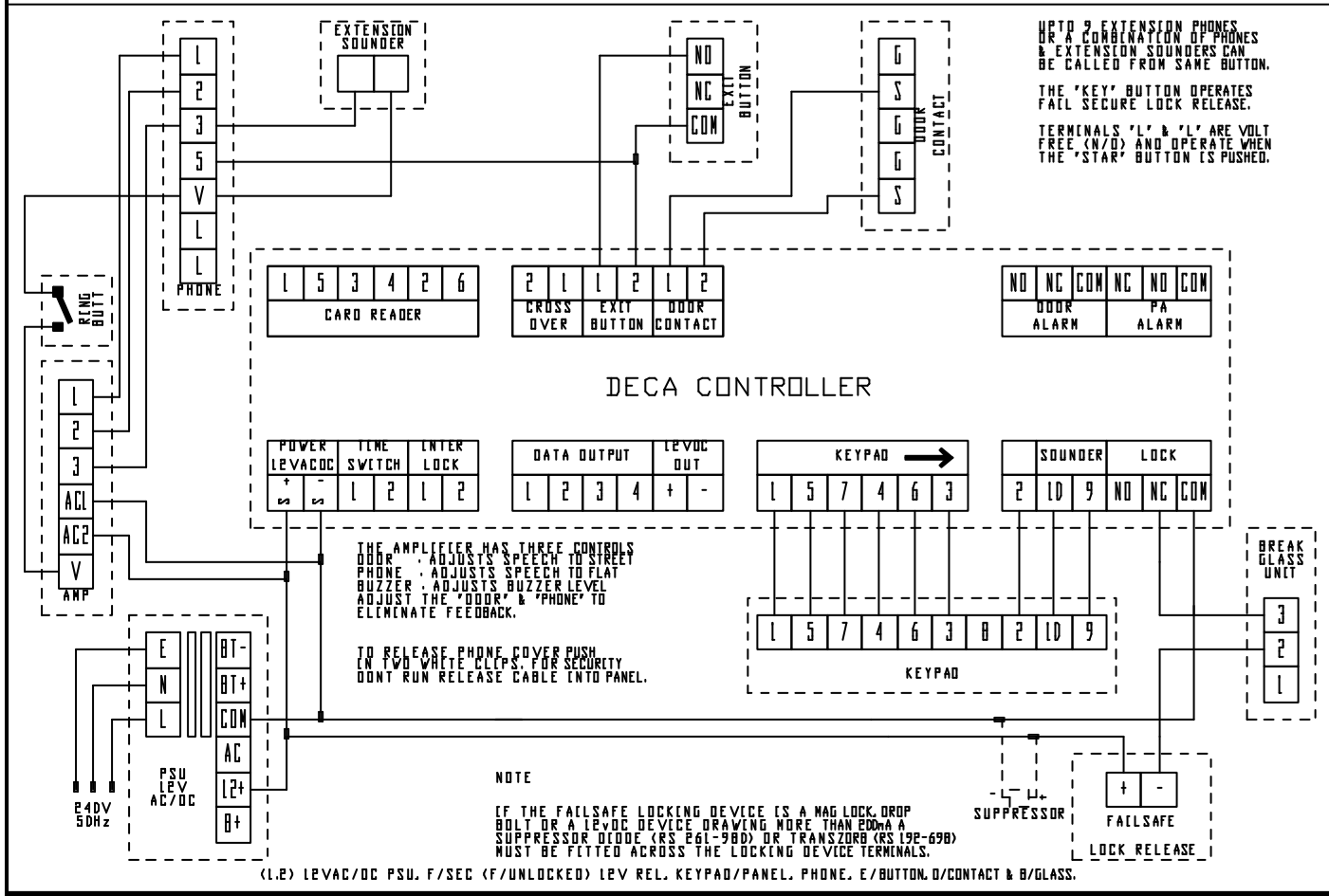
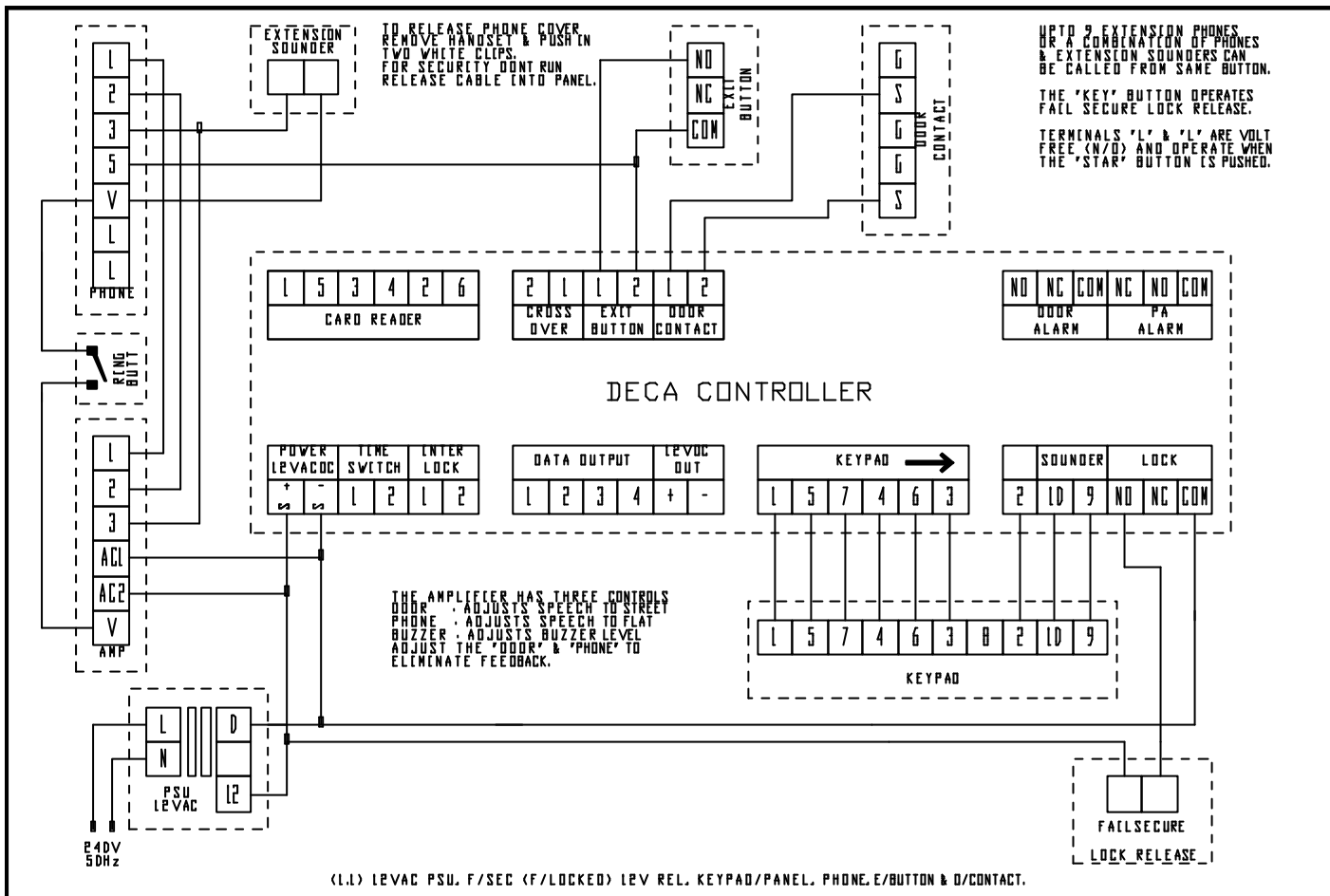

DATE	26-1-1999	DECA CODED/AUDIO ACCESS CONTROL SYSTEM (1.1) LEVAC PSU, F/SEC (F/LOCKED) LEV REL, KEYPAD/PANEL, PHONE, E/BUTTON & D/CONTACT. (1.2) LEVAC/DC PSU, F/SAF (F/UN/L) LEV REL, K/PAD/PAN, PHONE, E/BUTT, D/CONT & B/GLASS.	DRAWING NUMBER
ISSUE	DDL		DECA-CA
DRAWN	KGJ		010_008

